

Avnet Embedded.  
With you every step of the way.



## DATASHEET

# AUO

## G070VTN01.0

Date: September 2012

[www.avnet-embedded.eu](http://www.avnet-embedded.eu)



**If you require a touch panel solution.**

For information on touch sensors, sensor driving and touch panel bonding solutions, scan the QR code or click the URL

[www.avnet-embedded.eu/products/displays/html](http://www.avnet-embedded.eu/products/displays/html)



**Contents**

<b>1. Operating Precautions</b> .....	<b>4</b>
<b>2. General Description</b> .....	<b>5</b>
2.1 Display Characteristics.....	5
2.2 Optical Characteristics.....	6
<b>3. Functional Block Diagram</b> .....	<b>9</b>
<b>4. Absolute Maximum Ratings</b> .....	<b>10</b>
4.1 Absolute Ratings of TFT LCD Module.....	10
4.2 Absolute Ratings of Environment.....	10
<b>5. Electrical Characteristics</b> .....	<b>11</b>
5.1 TFT LCD Module.....	11
5.2 Backlight Unit.....	13
<b>6. Signal Characteristic</b> .....	<b>14</b>
6.1 Pixel Format Image.....	14
6.2 Signal Description.....	15
6.4 The Input Data Format.....	17
6.5 Interface Timing.....	18
6.6 Power ON/OFF Sequence.....	19
<b>7. Connector &amp; Pin Assignment</b> .....	<b>20</b>
7.1 TFT LCD Signal (CN1): LVDS Connector.....	20
7.2 LED Backlight Unit (CN2): LED Driver Connector.....	20
<b>8. Reliability Test Criteria</b> .....	<b>21</b>
<b>9. Mechanical Characteristics</b> .....	<b>22</b>
9.1 LCM Outline Dimension (Front View).....	22
9.2 LCM Outline Dimension (Rear View).....	22
<b>10. Label and Packaging</b> .....	<b>24</b>
10.1 Shipping Label (on the rear side of TFT-LCD display).....	24
10.2 Carton Package.....	24
<b>11 Safety</b> .....	<b>25</b>
11.1 Sharp Edge Requirements.....	25
11.2 Materials.....	25
11.3 Capacitors.....	25
11.4 National Test Lab Requirement.....	25

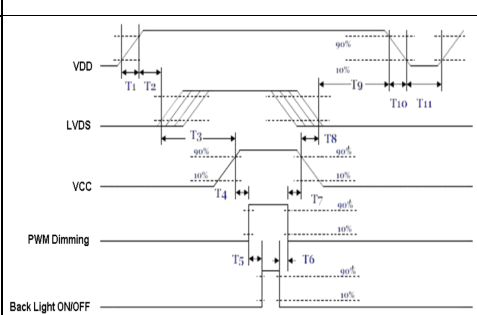
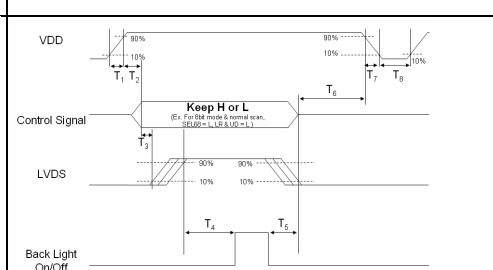
Version Date	Page	Old description	New Description																																																																																																															
V 0.2	19	LED Backlight Unit:	LED Backlight Unit:																																																																																																															
	21,22	Original 2D outline	Updated 2D outline including: 1. New 2D outline with mounting holes 2. New LED cable length defined																																																																																																															
V 0.3	20	LED Cable Maker changed	JST connector chosen																																																																																																															
V 0.4	19	 <table border="1" data-bbox="574 985 845 1209"> <thead> <tr> <th rowspan="2">Parameter</th> <th colspan="3">Value</th> <th rowspan="2">Units</th> </tr> <tr> <th>Min.</th> <th>Typ.</th> <th>Max.</th> </tr> </thead> <tbody> <tr> <td>T1</td> <td>0.5</td> <td>-</td> <td>10</td> <td>[ms]</td> </tr> <tr> <td>T2</td> <td>30</td> <td>40</td> <td>50</td> <td>[ms]</td> </tr> <tr> <td>T3</td> <td>175</td> <td>-</td> <td>-</td> <td>[ms]</td> </tr> <tr> <td>T4</td> <td>10</td> <td>-</td> <td>-</td> <td>[ms]</td> </tr> <tr> <td>T5</td> <td>10</td> <td>-</td> <td>-</td> <td>[ms]</td> </tr> <tr> <td>T6</td> <td>0</td> <td>-</td> <td>-</td> <td>[ms]</td> </tr> <tr> <td>T7</td> <td>10</td> <td>-</td> <td>-</td> <td>[ms]</td> </tr> <tr> <td>T8</td> <td>100</td> <td>-</td> <td>-</td> <td>[ms]</td> </tr> <tr> <td>T9</td> <td>0</td> <td>16</td> <td>50</td> <td>[ms]</td> </tr> <tr> <td>T10</td> <td>-</td> <td>-</td> <td>10</td> <td>[ms]</td> </tr> <tr> <td>T11</td> <td>1000</td> <td>-</td> <td>-</td> <td>[ms]</td> </tr> </tbody> </table>	Parameter	Value			Units	Min.	Typ.	Max.	T1	0.5	-	10	[ms]	T2	30	40	50	[ms]	T3	175	-	-	[ms]	T4	10	-	-	[ms]	T5	10	-	-	[ms]	T6	0	-	-	[ms]	T7	10	-	-	[ms]	T8	100	-	-	[ms]	T9	0	16	50	[ms]	T10	-	-	10	[ms]	T11	1000	-	-	[ms]	 <p>Note : Control signal indicates UD, LR and SEL68.</p> <table border="1" data-bbox="1037 985 1308 1187"> <thead> <tr> <th rowspan="2">Parameter</th> <th colspan="3">Value</th> <th rowspan="2">Units</th> </tr> <tr> <th>Min.</th> <th>Typ.</th> <th>Max.</th> </tr> </thead> <tbody> <tr> <td>T1</td> <td>0.5</td> <td>-</td> <td>10</td> <td>ms</td> </tr> <tr> <td>T2</td> <td>10</td> <td>-</td> <td>-</td> <td>ms</td> </tr> <tr> <td>T3</td> <td>30</td> <td>40</td> <td>50</td> <td>ms</td> </tr> <tr> <td>T4</td> <td>200</td> <td>-</td> <td>-</td> <td>ms</td> </tr> <tr> <td>T5</td> <td>100</td> <td>-</td> <td>-</td> <td>ms</td> </tr> <tr> <td>T6</td> <td>0</td> <td>16</td> <td>50</td> <td>ms</td> </tr> <tr> <td>T7</td> <td>-</td> <td>-</td> <td>10</td> <td>ms</td> </tr> <tr> <td>T8</td> <td>1000</td> <td>-</td> <td>-</td> <td>ms</td> </tr> </tbody> </table>	Parameter	Value			Units	Min.	Typ.	Max.	T1	0.5	-	10	ms	T2	10	-	-	ms	T3	30	40	50	ms	T4	200	-	-	ms	T5	100	-	-	ms	T6	0	16	50	ms	T7	-	-	10	ms	T8	1000	-	-	ms
Parameter	Value			Units																																																																																																														
	Min.	Typ.	Max.																																																																																																															
T1	0.5	-	10	[ms]																																																																																																														
T2	30	40	50	[ms]																																																																																																														
T3	175	-	-	[ms]																																																																																																														
T4	10	-	-	[ms]																																																																																																														
T5	10	-	-	[ms]																																																																																																														
T6	0	-	-	[ms]																																																																																																														
T7	10	-	-	[ms]																																																																																																														
T8	100	-	-	[ms]																																																																																																														
T9	0	16	50	[ms]																																																																																																														
T10	-	-	10	[ms]																																																																																																														
T11	1000	-	-	[ms]																																																																																																														
Parameter	Value			Units																																																																																																														
	Min.	Typ.	Max.																																																																																																															
T1	0.5	-	10	ms																																																																																																														
T2	10	-	-	ms																																																																																																														
T3	30	40	50	ms																																																																																																														
T4	200	-	-	ms																																																																																																														
T5	100	-	-	ms																																																																																																														
T6	0	16	50	ms																																																																																																														
T7	-	-	10	ms																																																																																																														
T8	1000	-	-	ms																																																																																																														

## 1. Operating Precautions

- 1) Since front polarizer is easily damaged, please be cautious not to scratch it.
- 2) Be sure to turn off power supply when inserting or disconnecting from input connector.
- 3) Wipe off water drop immediately. Long contact with water may cause discoloration or spots.
- 4) When the panel surface is soiled, wipe it with absorbent cotton or soft cloth.
- 5) Since the panel is made of glass, it may be broken or cracked if dropped or bumped on hard surface.
- 6) To avoid ESD (Electro Static Discharge) damage, be sure to ground yourself before handling TFT-LCD Module.
- 7) Do not open nor modify the module assembly.
- 8) Do not press the reflector sheet at the back of the module to any direction.
- 9) In case if a module has to be put back into the packing container slot after it was taken out from the container, do not press the center of the LED Reflector edge. Instead, press at the far ends of the LED Reflector edge softly. Otherwise the TFT Module may be damaged.
- 10) At the insertion or removal of the Signal Interface Connector, be sure not to rotate nor tilt the Interface Connector of the TFT Module.
- 11) After installation of the TFT Module into an enclosure (Notebook PC Bezel, for example), do not twist nor bend the TFT Module even momentarily. At designing the enclosure, it should be taken into consideration that no bending/twisting forces are applied to the TFT Module from outside. Otherwise the TFT Module may be damaged.
- 12) Small amount of materials having no flammability grade is used in the LCD module. The LCD module should be supplied by power complied with requirements of Limited Power Source (IEC60950 or UL1950), or be applied exemption.
- 13) Severe temperature condition may result in different luminance, response time.
- 14) Continuous operating TFT-LCD Module under high temperature environment may accelerate LED light bar exhaustion and reduce luminance dramatically.
- 15) The data on this specification sheet is applicable when LCD module is placed in landscape position.
- 16) Continuous displaying fixed pattern may induce image sticking. It is recommended to use screen saver or shuffle content periodically if fixed pattern is displayed on the screen.

## 2. General Description

This specification applies to the 7.0 inch color TFT LCD module G070VTN01.0.

G070VTN01.0 is built in timing controller and LVDS interface. The screen format is intended to support the WVGA (800(H) x 480(V)) screen and 16.2M (RGB 8-bits) or 262k colors (RGB 6-bits). G070VTN01.0 is a RoHS product.

### 2.1 Display Characteristics

The following items are characteristics summary on the table under 25 °C condition:

Items	Unit	Specifications
Screen Diagonal	[inch]	7.0 ( 177.8mm )
Active Area	[mm]	152.40(H) x 91.44(V)
Pixels H x V		800(H) x 480RGB(V)
Pixel Pitch	[mm]	0.1905 x 0.1905
Pixel Arrangement		R.G.B. Horizontal Stripe
Display Mode		TN, Normally White
Nominal Input Voltage VDD	[Volt]	3.3 typ.
LCD Typical Power Consumption	[Watt]	0.33
Back Light Power Consumption	[Watt]	1.47
Weight	[Grams]	TBD
Physical Size	[mm]	170.0(W) x 111.0(H) x 8.0(D) (typ.)
Electrical Interface		1 channel LVDS
Surface Treatment		Anti-glare, Hardness 3H
Support Color		262K(6-bit) / 16.2M(8-bit)
Temperature Range Operating Storage (Non-Operating)	[°C] [°C]	-20 to +70 -30 to +80
RoHS Compliance		RoHS Compliance

## 2.2 Optical Characteristics

The optical characteristics are measured under stable conditions at 25°C (Room Temperature):

Item	Unit	Conditions	Min.	Typ.	Max.	Note
White Luminance	[cd/m <sup>2</sup> ]	I <sub>F</sub> = 20mA (center point)	250	300	-	1
Uniformity	%	5 Points			1.3	1.2.3
Contrast Ratio			400	500	-	4
Response Time	[msec]	Rising	-	12	20	5
	[msec]	Falling	-	18	30	
	[msec]	Rising + Falling	-	30	50	
Viewing Angle	[degree]	Horizontal CR ≥ 10 (Right) (Left)	55	65	-	6
	[degree]		55	65	-	
	[degree]	Vertical CR ≥ 10 (Upper) (Lower)	40	50	-	
Color / Chromaticity Coordinates (CIE 1931)		Red x	TBD	TBD	TBD	1
		Red y	TBD	TBD	TBD	
		Green x	TBD	TBD	TBD	
		Green y	TBD	TBD	TBD	
		Blue x	TBD	TBD	TBD	
		Blue y	TBD	TBD	TBD	
		White x	TBD	TBD	TBD	
		White y	TBD	TBD	TBD	
Color Gamut	%		-	50	-	1

Note 1: Measurement method

Equipment: Pattern Generator, Power Supply, Digital Voltmeter, Luminance meter (SR\_3 or equivalent)

Scanning Direction : Normal Scan

Aperture 1" with 50cm viewing distance

Test Point Center,

Environment < 1 lux

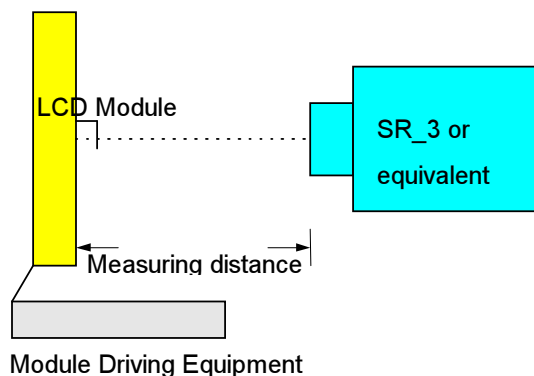

Note 2: Definition of 5 points position (Display active area: 152.40(H) x 91.44(V))

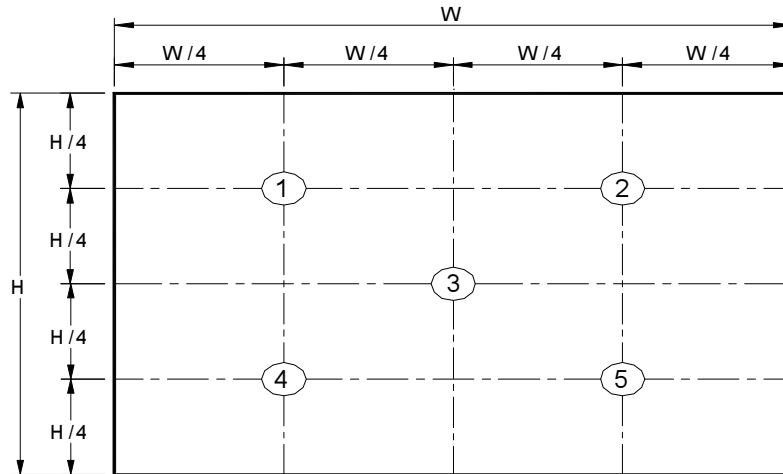

Note 3:  
The luminance uniformity of 5 points is defined by dividing the maximum luminance value by the minimum luminance value at full white condition.

$$\delta_{w5} = \frac{\text{Maximum Brightness of five points}}{\text{Minimum Brightness of five points}}$$

Note 4 : Definition of contrast ratio (CR):

$$\text{Contrast ratio (CR)} = \frac{\text{Brightness on the "White" state}}{\text{Brightness on the "Black" state}}$$

Note 5: Definition of response time:

The output signals of photo detector are measured when the input signals are changed from "White" to "Black" (falling time) and from "Black" to "White" (rising time), respectively. The response time interval is between 10% and 90% of amplitudes. Please refer to the figure as below.

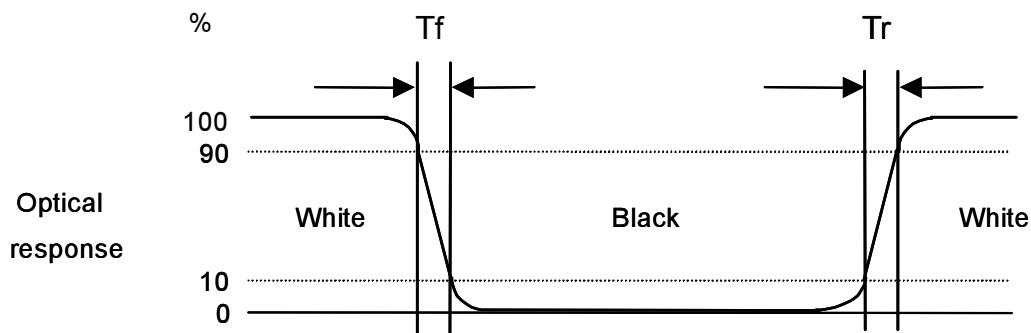



Note 6: Definition of viewing angle

Viewing angle is the measurement of contrast ratio  $\geq 10$ , at the screen center, over a  $180^\circ$  horizontal and  $180^\circ$  vertical range (off-normal viewing angles). The  $180^\circ$  viewing angle range is broken down as below:  $90^\circ$  ( $\theta$ ) horizontal left and right, and  $90^\circ$  ( $\Phi$ ) vertical high (up) and low (down). The measurement direction is typically perpendicular to the display surface with the screen rotated to its center to develop the desired measurement viewing angle.

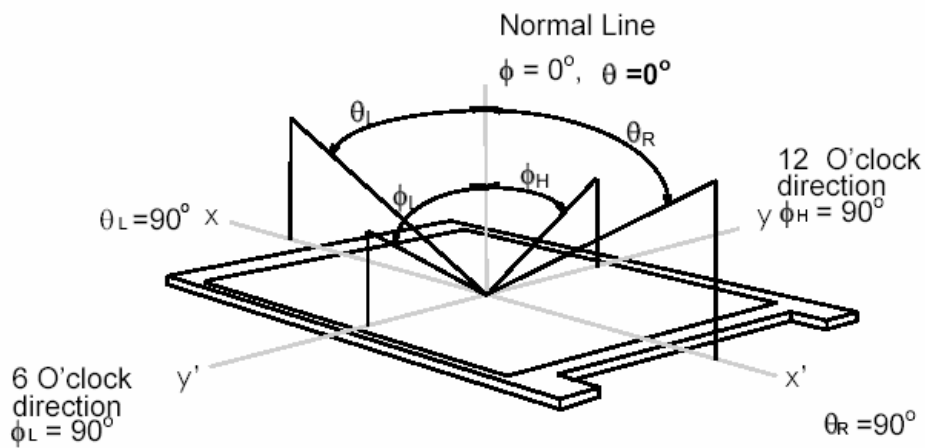



## 4. Absolute Maximum Ratings

### 4.1 Absolute Ratings of TFT LCD Module

Item	Symbol	Min	Max	Unit	Conditions
Logic/LCD Drive Voltage	VDD	-0.3	+3.6	[Volt]	

### 4.2 Absolute Ratings of Environment

Item	Symbol	Min	Max	Unit
Operating Temperature	TOP	-20	+70	[°C]
Operation Humidity	HOP	5	90	[%RH]
Storage Temperature	TST	-30	+80	[°C]
Storage Humidity	HST	5	90	[%RH]

Note: Maximum Wet-Bulb should be 39°C and no condensation.

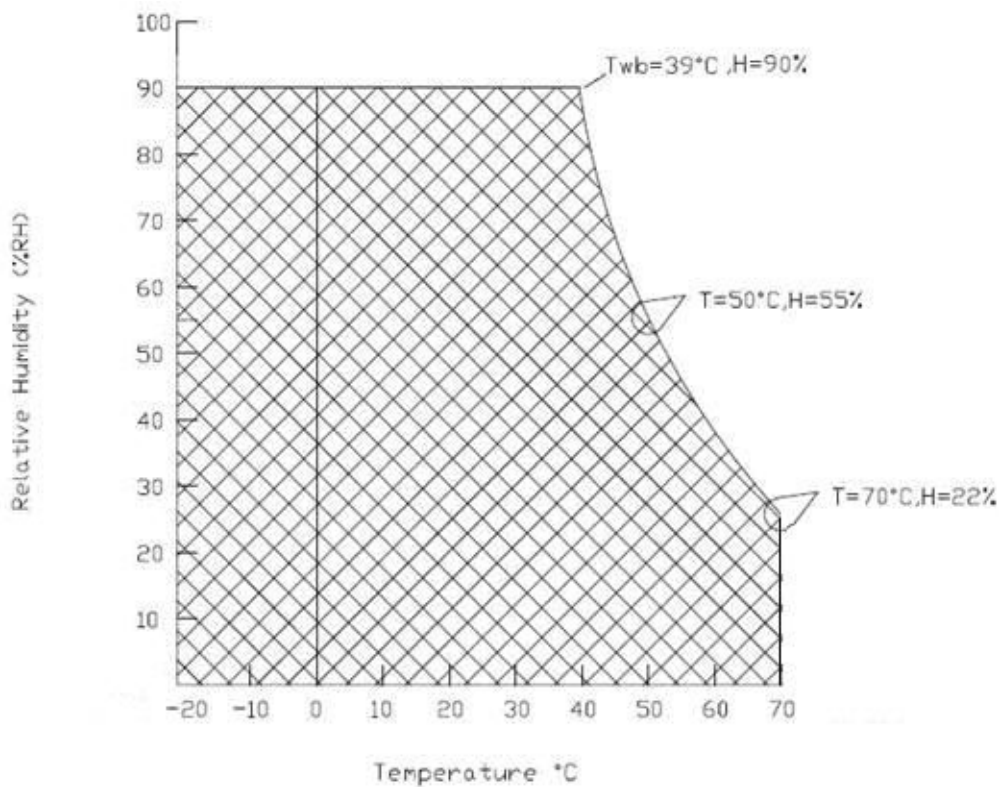

## 5. Electrical Characteristics

### 5.1 TFT LCD Module

#### 5.1.1 Power Specification

Symbol	Parameter	Min	Typ	Max	Units	Remark
VDD	Logic/LCD Drive Voltage	3.0	3.3	3.6	[Volt]	±10%
I <sub>VDD</sub>	VDD Current	-	100	120	[mA]	64 Gray Bar Pattern (VDD=3.3V, at 60Hz)
I <sub>rush</sub>	LCD Inrush Current	-	-	1	[A]	Note 1
P <sub>VDD</sub>	VDD Power	-	0.33	0.43	[Watt]	64 Gray Bar Pattern (VDD=3.3V, at 60Hz)

Note 1: Measurement condition:

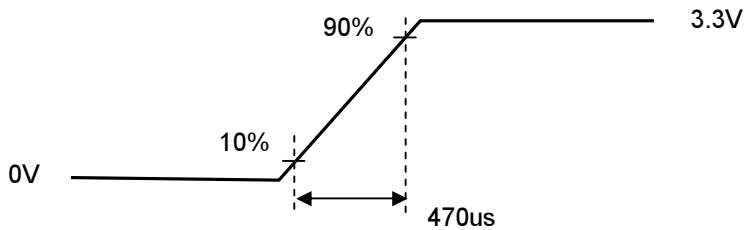
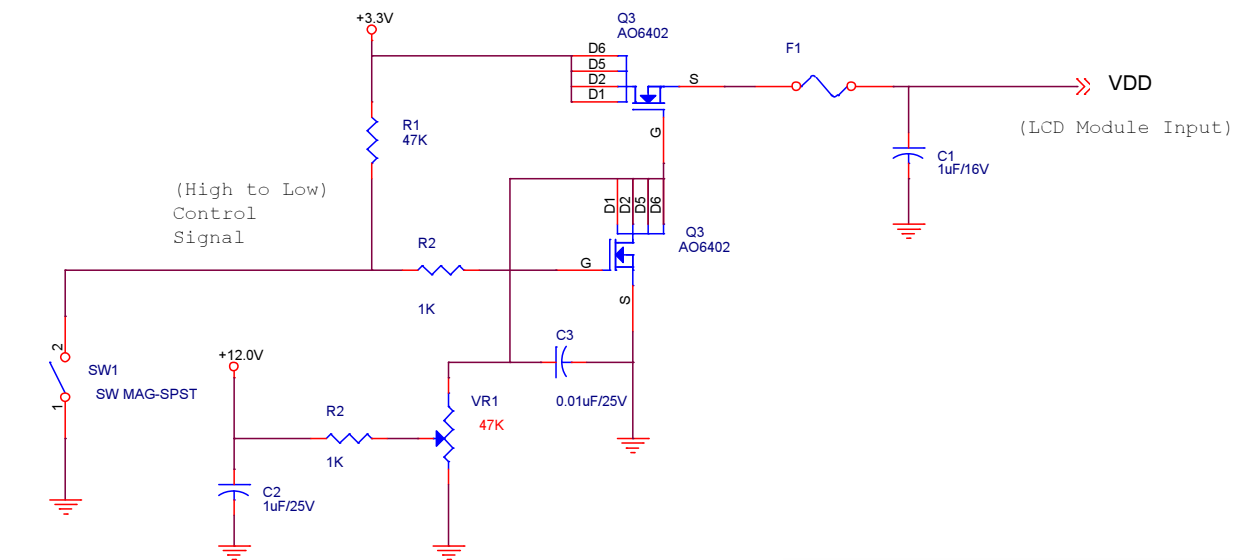

VDD rising time



64 Gray pattern

### 5.1.2 Signal Electrical Characteristics

Input signals shall be low or Hi-Z state when VDD is off.

Symbol	Item	Min.	Typ.	Max.	Unit	Remark
VTH	Differential Input High Threshold	-	-	100	[mV]	VICM=1.2V
VTL	Differential Input Low Threshold	-100	-	-	[mV]	VICM=1.2V
VID	Input Differential Voltage	100	400	600	[mV]	
VICM	Differential Input Common Mode Voltage	1.1		1.6	[V]	VTH/VTL=±100mV

Note: LVDS Signal Waveform.

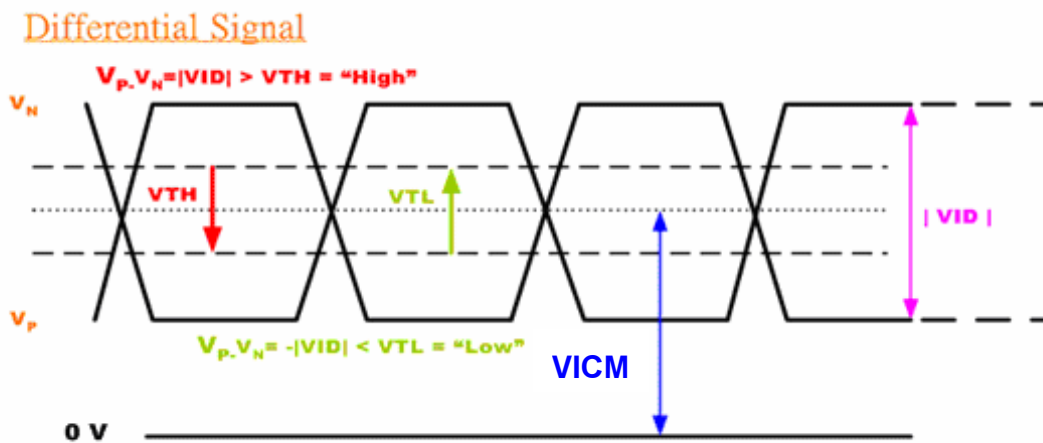

## 5.2 Backlight Unit

### 5.2.1 Parameter guideline for LED

Following characteristics are measured under a stable condition using an inverter at 25 °C (Room Temperature): The backlight (LED module, Note 1) is suggested to drive by constant current 140mA.

Parameter	Symbol	Min.	Typ.	Max.	Unit	Remark
LED light bar Voltage	$V_L$		9.6	10.5	V	$I_F=140mA$
Power Consumption	$P_{BL}$	1.218	1.344	1.47	W	Note 1
LED Life Time	$L_L$	30,000	--	--	Hr	Note 2, 3

Note 1: The LED driving condition is defined for LED module (21 LED). The voltage range will be up to 10.5V based on suggested driving current set as 140mA.

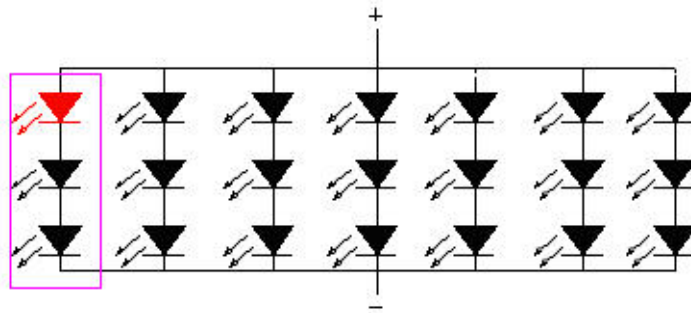

Note 2: Define “LED Lifetime”: brightness is decreased to 50% of the initial value. LED Lifetime is restricted under normal condition, ambient temperature = 25°C and LED light bar current = 140mA.

Note 3: If it uses larger LED light bar voltage/ current more than 10.5V/140mA, it maybe decreases the LED lifetime.

## 6. Signal Characteristic

### 6.1 Pixel Format Image

Following figure shows the relationship between input signal and LCD pixel format.

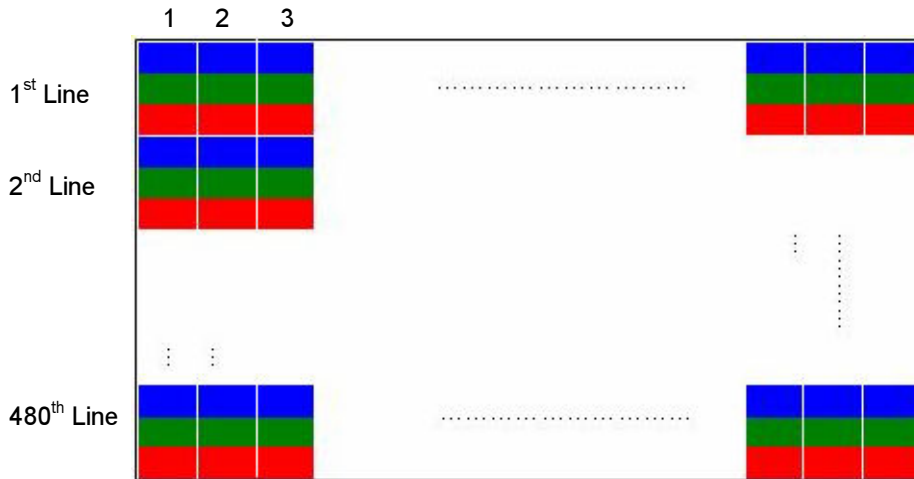

## 6.2 Signal Description

LVDS is a differential signal technology for LCD interface and high speed data transfer device. The connector pin definition is as below.

Pin No.	Symbol	Description
1	VDD	Power Supply, 3.3V (typical)
2	VDD	Power Supply, 3.3V (typical)
3	UD	Vertical Reverse Scan Control, When UD=Low or NC → Normal Mode. When UD=High → Vertical Reverse Scan. <small>Note</small>
4	LR	Horizontal Reverse Scan Control, When LR=Low or NC → Normal Mode. When LR=High → Horizontal Reverse Scan. <small>Note</small>
5	RxIN1-	LVDS differential data input Pair 0
6	RxIN1+	
7	GND	Ground
8	RxIN2-	LVDS differential data input Pair 1
9	RxIN2+	
10	GND	Ground
11	RxIN3-	LVDS differential data input Pair 2
12	RxIN3+	
13	GND	Ground
14	RxCLKIN-	LVDS differential Clock input Pair
15	RxCLKIN+	
16	GND	Ground
17	SEL 68	LVDS 6/8 bit select function control, High or NC → 6 Bit Input Mode. Low → 8 Bit Input Mode. <small>Note</small>
18	NC	NC
19	RxIN4-	LVDS differential data input Pair 3.
20	RxIN4+	

Note1 : “Low” stands for 0V. “High” stands for 3.3V. “NC” stands for “No Connected.”

Note2: For 6 bits input mode, pin 19 and pin 20 must be floated.



## 6.3 Scanning Direction

The following figures show the image seen from the front view. The arrow indicates the direction of scan.

The UD/RL pin setting should follow the power on sequence in Section 6.6.

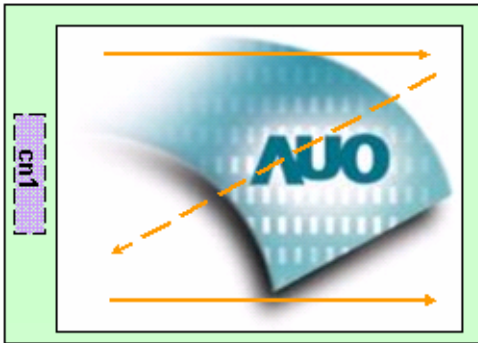

Fig. 1

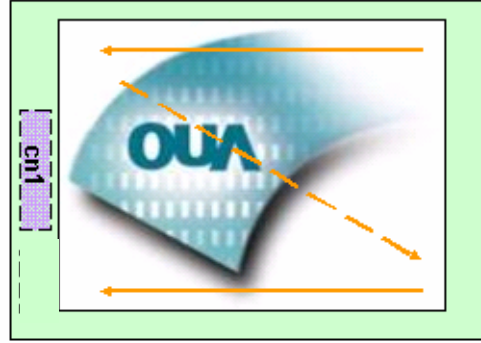

Fig. 2

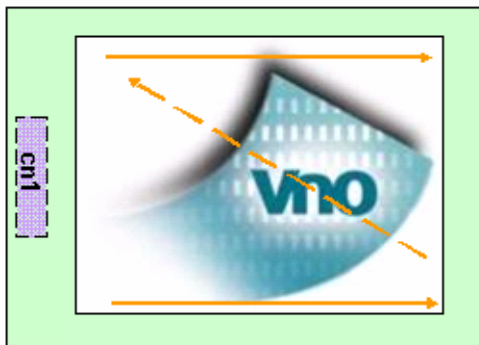

Fig. 3

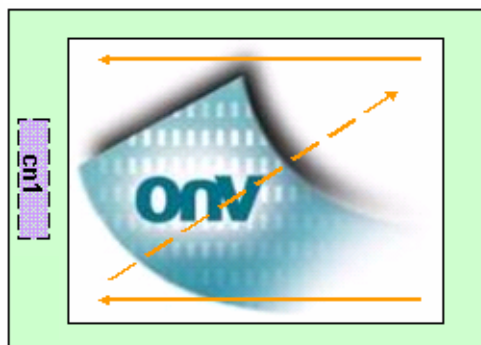

Fig. 4

Fig. 1 Normal scan (Pin3, UD = Low or NC ; Pin4, RL = Low or NC)

Fig. 2 Reverse scan (Pin3, UD = Low or NC ; Pin4, RL = High)

Fig. 3 Reverse scan (Pin3, UD = High ; Pin4, RL = Low or NC)

Fig. 4 Reverse scan (Pin3, UD = High ; Pin4, RL = High)

## 6.4 The Input Data Format

### 6.4.1 SEL68

**SEL68 = "High" or "NC" for 6 bits LVDS Input**

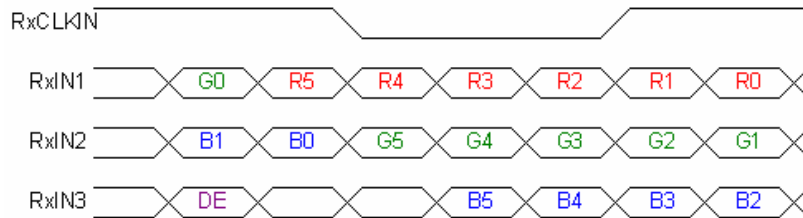

**SEL68 = "Low" for 8 bits LVDS Input**

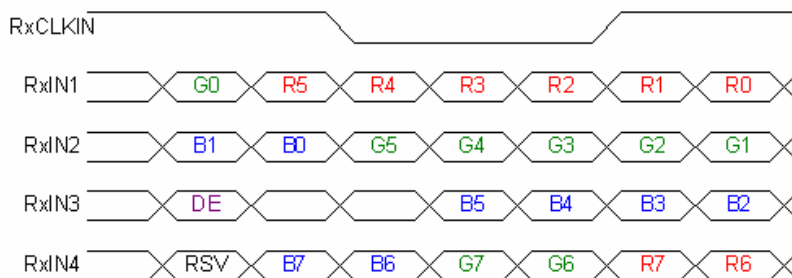

Signal Name	Description	Remark
R7 R6 R5 R4 R3 R2 R1 R0	Red Data 7 (MSB) Red Data 6 Red Data 5 Red Data 4 Red Data 3 Red Data 2 Red Data 1 Red Data 0 (LSB)	Red-pixel Data Each red pixel's brightness data consists of these 8 bits pixel data.
G7 G6 G5 G4 G3 G2 G1 G0	Green Data 7 (MSB) GreenData 6 GreenData 5 GreenData 4 GreenData 3 GreenData 2 GreenData 1 GreenData 0 (LSB)	Green-pixel Data Each green pixel's brightness data consists of these 8 bits pixel data.
B7 B6 B5 B4 B3 B2 B1 B0	Blue Data 7 (MSB) Blue Data 6 Blue Data 5 Blue Data 4 Blue Data 3 Blue Data 2 Blue Data 1 Blue Data 0 (LSB)	Blue-pixel Data Each blue pixel's brightness data consists of these 8 bits pixel data.
RxCLKIN+	LVDS Clock Input	
RxCLKIN-		
DE	Display Enable	
RSV	Reserved Signal	"High" or "Low" is acceptable

Note: Output signals from any system shall be low or Hi-Z state when VDD is off.

## 6.5 Interface Timing

### 6.5.1 Timing Characteristics

DE mode only

Parameter	Symbol	Min.	Typ.	Max.	Unit	Condition
Clock frequency	$1/T_{Clock}$	30.3	33.26	37.8	MHz	
Vertical Section	Period	$T_V$	517	525	532	$T_H$
	Active	$T_{VD}$	-	480	-	
	Blanking	$T_{VB}$	37	45	52	
Horizontal Section	Period	$T_H$	986	1056	1183	$T_{Clock}$
	Active	$T_{HD}$	-	800	-	
	Blanking	$T_{HB}$	186	256	383	

Note: Frame rate is 60 Hz.

### 6.5.2 Input Timing Diagram

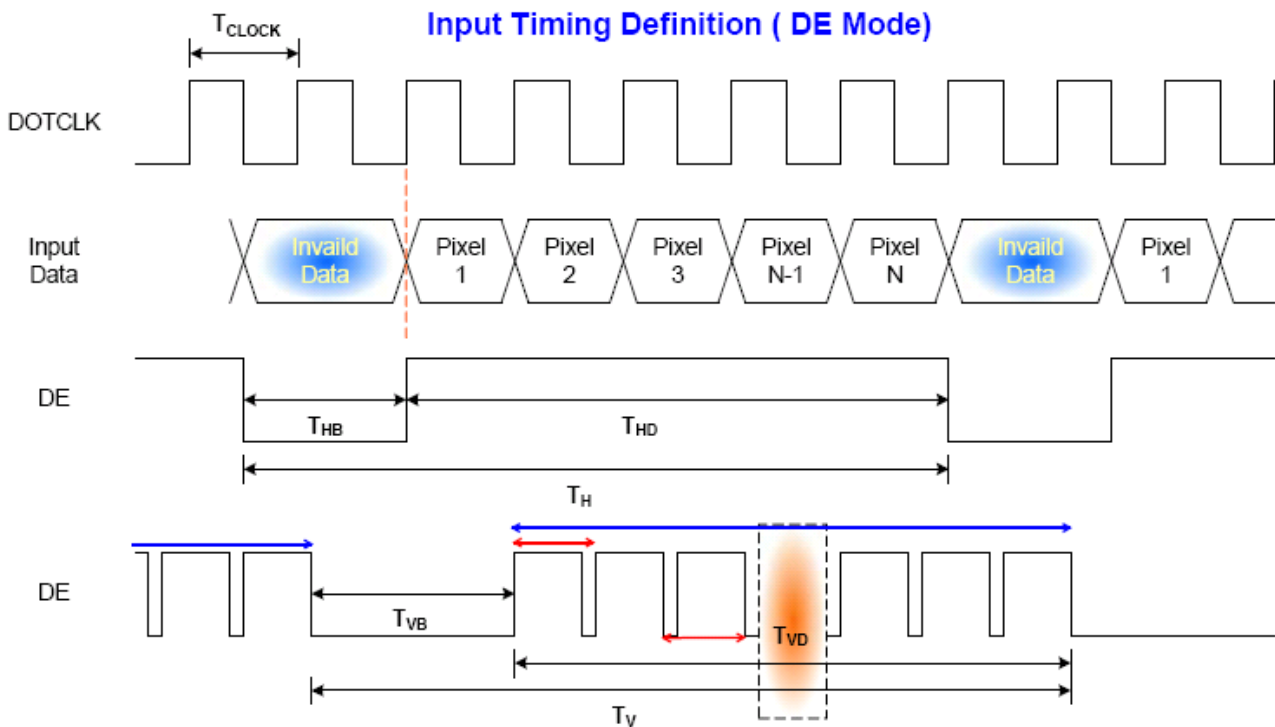

## 6.6 Power ON/OFF Sequence

VDD power and backlight on/off sequence is as below. Interface signals are also shown in the chart. Signals from any system shall be Hi-Z state or low level when VDD is off.

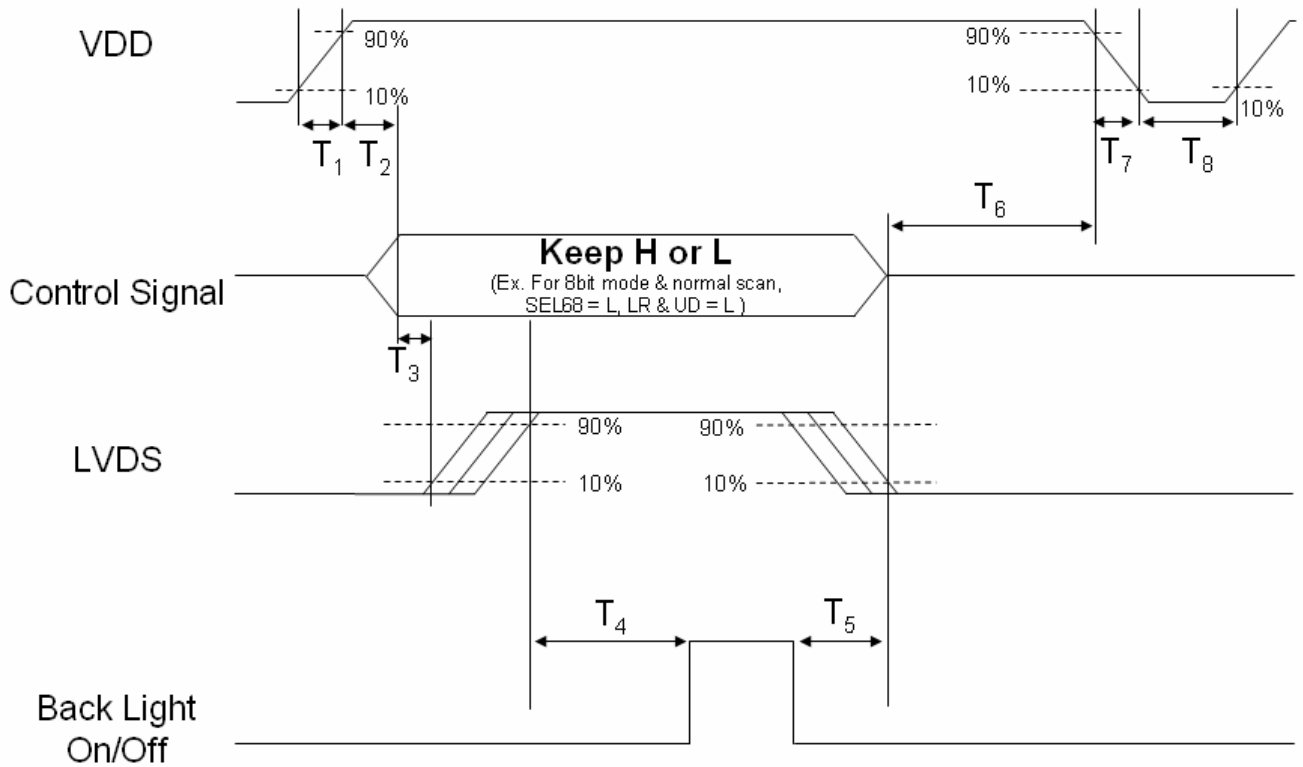

Note : Control signal indicates UD, LR and SEL68.

Parameter	Value			Units
	Min.	Typ.	Max.	
T <sub>1</sub>	0.5	-	10	ms
T <sub>2</sub>	10	-	-	ms
T <sub>3</sub>	30	40	50	ms
T <sub>4</sub>	200	-	-	ms
T <sub>5</sub>	100	-	-	ms
T <sub>6</sub>	0	16	50	ms
T <sub>7</sub>	-	-	10	ms
T <sub>8</sub>	1000	-	-	ms

The above on/off sequence should be applied to avoid abnormal function in the display. Please make sure to turn off the power when you plug the cable into the input connector or pull the cable out of the connector.

## 7. Connector & Pin Assignment

Physical interface is described as for the connector on module. These connectors are capable of accommodating the following signals and will be following components.

### 7.1 TFT LCD Signal (CN1): LVDS Connector

Connector Name / Designation	Signal Connector
Manufacturer	Hirose or compatible
Connector Model Number	Hirose-DF19LA-20P-1H or compatible
Mating Model Number	Hirose-DF19-20S-1C or compatible

Pin No.	Signal Name	Pin No.	Signal Name
1	VDD	2	VDD
3	UD	4	LR
5	RxIN1-	6	RxIN1+
7	GND	8	RxIN2-
9	RxIN2+	10	GND
11	RxIN3-	12	RxIN3+
13	GND	14	RxCKIN-
15	RxCKIN+	16	GND
17	SEL 68	18	NC
19	RxIN4-	20	RxIN4+

### 7.2 LED Backlight Unit: LED Connector

Connector Name / Designation	LED Connector
Manufacturer	JST or compatible
Connector Model Number (Contact)	JST SSH003T-P0.2 or compatible
Mating Model Number (Housing)	JST SHR-02V-BK-B_HF(Halogen free) or compatible

Pin no	Symbol	I/O	Description	Remark
1	VLED	P	LED power supply	
2	GNDLED	P	LED ground	

## 8. Reliability Test Criteria

Items	Required Condition	Note
Temperature Humidity Bias	40□/90%,300 hours	
High Temperature Operation	70□,300 hours	
Low Temperature Operation	-20□,300 hours	
Hot Storage	80□,300 hours	
Cold Storage	-30□,300 hours	
Thermal Shock Test	-20□/30 min ,60□/30 min ,100cycles	
Shock Test (Non-Operating)	50G,20ms,Half-sine wave,( ±X, ±Y, ±Z)	
Vibration Test (Non-Operating)	1.5G, (10~200~10Hz, P-P) 30 mins/axis (X, Y, Z)	
On/off test	On/10 sec, Off/10 sec, 30,000 cycles	
ESD	Contact Discharge: ± 8KV, 150pF(330Ω ) 1sec, 8 points, 25 times/ point Air Discharge: ± 15KV, 150pF(330Ω ) 1sec, 8 points, 25 times/ point	Note 1

Note1: According to EN61000-4-2, ESD class B: Some performance degradation allowed. No data lost  
 . Self-recoverable. No hardware failures.



### 9.2 LCM Outline Dimension (Rear View)

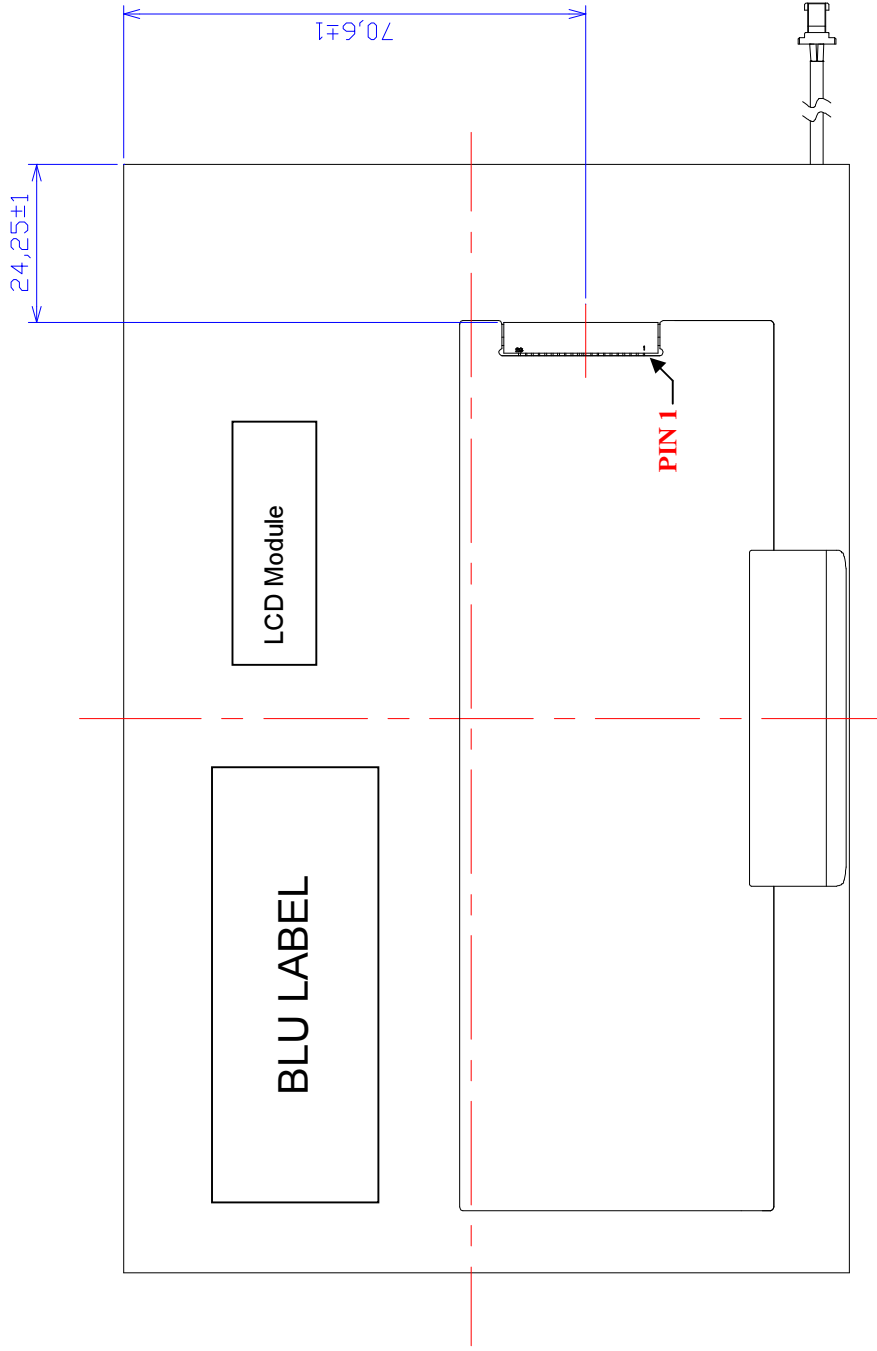



## 10. Label and Packaging

### 10.1 Shipping Label (on the rear side of TFT-LCD display)



### 10.2 Carton Package

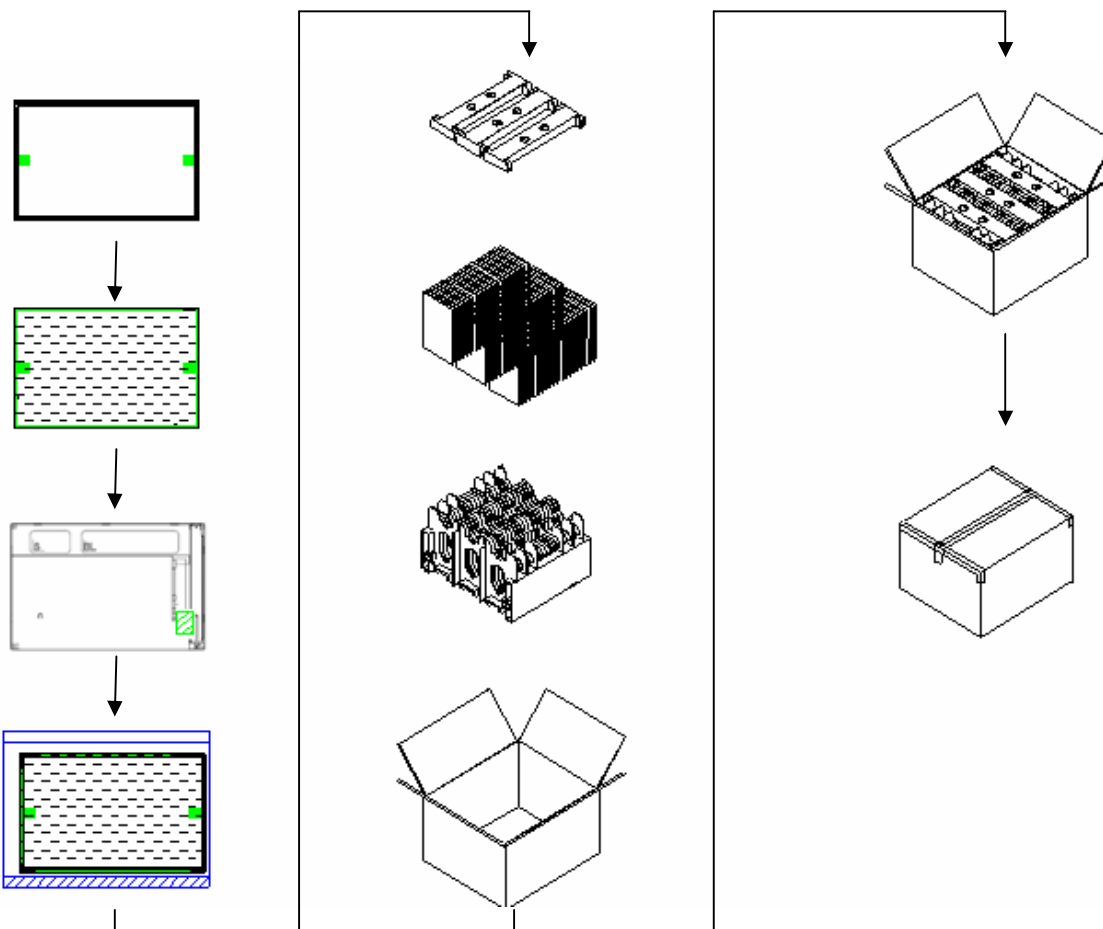

Note:

1. Max. Capacity: 60pcs LCD Modules / per carton
2. Max. Weight: 14.4 kg / per carton
3. The outside dimension of carton is 434(L) mm x 377(W) mm x 264(H) mm

## 11 Safety

### 11.1 Sharp Edge Requirements

There will be no sharp edges or corners on the display assembly that could cause injury.

### 11.2 Materials

#### 11.2.1 Toxicity

There will be no carcinogenic materials used anywhere in the display module. If toxic materials are used, they will be reviewed and approved by the responsible AUO toxicologist.

#### 11.2.2 Flammability

All components including electrical components that do not meet the flammability grade UL94-V1 in the module will complete the flammability rating exception approval process.

The pRxINted circuit board will be made from material rated 94-V1 or better. The actual UL flammability rating will be pRxINted on the pRxINted circuit board.

### 11.3 Capacitors

If any polarized capacitors are used in the display assembly, provisions will be made to keep them from being inserted backwards.

### 11.4 National Test Lab Requirement

The display module will satisfy all requirements for compliance to:

**UL 1950, First Edition**

**U.S.A. Information Technology Equipment**

## AVNET EMBEDDED OFFICES

### DENMARK

Avnet Embedded  
Avnet Nortec A/S  
Ellekær 9  
2730 Herlev  
Phone: +45 3678 6250  
Fax: +45 3678 6255  
denmark@avnet-embedded.eu

### FINLAND

Avnet Embedded  
Avnet Nortec Oy  
Pihatörmä 1 B  
02240 Espoo  
Phone: +358 20 749 9 260  
Fax: +358 20 749 9 280  
finland@avnet-embedded.eu

### FRANCE

Avnet Embedded  
Avnet EMG France SA  
Parc Club du Moulin à Vent, Bât 10  
33, rue du Dr Georges Lévy  
69693 Vénissieux Cedex  
Phone: +33 4 78 77 13 92  
Fax: +33 4 78 77 13 97  
bron@avnet-embedded.eu

Avnet Embedded  
Avnet EMG France SA  
14 avenue Carnot  
91349 Massy Cedex  
Phone: +33 1 64 47 29 29  
Fax: +33 1 64 47 99 99  
paris@avnet-embedded.eu

Avnet Embedded  
Avnet EMG France SA  
Les Peupliers II  
35 avenue des Peupliers  
35510 Cesson-Sévigné  
Phone: + 33 2 99 77 37 02  
Fax: + 33 2 99 77 37 01  
rennes@avnet-embedded.eu

### GERMANY (AUSTRIA, CZECH REPUBLIC, HUNGARY, POLAND, SWITZERLAND)

Avnet Embedded  
Avnet EMG GmbH  
Gruber Straße 60c  
85586 Poing  
Phone: +49 8121 775 500  
Fax: +49 8121 775 550  
poing@avnet-embedded.eu

Avnet Embedded  
Avnet EMG GmbH  
Lötscher Weg 66  
41334 Nettetal  
Phone: +49 8121 775 500  
Fax: +49 8121 775 550  
nettetal@avnet-embedded.eu

### ITALY (PORTUGAL, SPAIN)

Avnet Embedded  
Avnet EMG Italy SRL  
Via Manzoni, 44  
20095 Cusano Milanino  
Phone: +39 02 660 92 1  
Fax: +39 02 660 92 498  
milano@avnet-embedded.eu

### NETHERLANDS (BELGIUM, LUXEMBOURG)

Avnet Embedded  
Avnet B.V.  
Takkebijsters 2  
4817 BL Breda  
Phone: +31 76 5722400  
Fax: +31 76 5722404  
benelux@avnet-embedded.eu

### SWEDEN (NORWAY)

Avnet Embedded  
Avnet Nortec AB  
Esplanaden 3 D  
172 67 Sundbyberg  
Phone: +46 8 564 725 50  
Fax: +46 8 760 01 10  
sweden@avnet-embedded.eu

### UNITED KINGDOM (IRELAND)

Avnet Embedded  
5a Waltham Park  
White Waltham  
Maidenhead  
Berkshire, SL6 3TN  
Phone: +44 1628 518900  
Fax: +44 1628 518901  
uk@avnet-embedded.eu

All trademarks and logos are the property of their respective owners. No guarantee as to the accuracy, completeness or reliability of any information. Subject to modifications and amendments.