

# MULTI INPUT INDICATOR

## PRI-3000 SERIES



### FEATURE

- Universal input mode (mV, V, T/C, RTD, 2wire, mA)
- It is realized high effectiveness and high accuracy use by 16bit A/D converter.
- It contains peak hold function so possible to use various application.
- Relay alarm output selectable(optional)and dead band function contains.
- Isolated current output(4~20mA optional)also possible with scaling function.
- Contain burnout function that give high output and display warning message when sensor line was disconnected by accident or other reasons.

### GENERAL SPECIFICATIONS

Power Supply	DC 24V Type AC 24V Type AC Type	DC18V ~ 30V, (ripple 10%)100mA AC12V ~ 26V(50~60Hz), 4VA AC110/220V 60Hz ±10%, 4VA
Display Accuracy	-9999~9999, 7Segment 4 Digit ±0.2% Full Scale, ±1 Digit ( 25°C ±5°C )	
Input Impedance	V Type mV, V, mA PT100 Ω, T/C Type	400KΩ 1M Ω
Sampling cycle	V Type Pt100 Ω, T/C Type	200ms 400ms
CMRR(Common Mode Rejection Ratio) NMRR(Normal Mode Rejection Ratio) Sensor Power Temp Coefficient Insulation Resistance	140dB or more 50dB or more DC 24V / 30mA (±5% or less ) ±0.015% / °C Greater then 100MΩ with DC500V	
Dielectric Strength	Input - Power Output-Power GND - Power	AC2500V AC1000V 1 minute
Operating Temperature / Humidity Storage Temperature / Humidity Dimensions Case Material Weight Mounting	-20~60°C / 90% (N.C) -20~80°C / 95% (N.C) W96×H48×D112(mm) ABS Resin(white) about 400g Panel mounting Type	

### MULTI RANGE INPUT

Free input selection by code

Input	Range of input and scale	MIN Span	Message
T/C	R (PR 13%)	0~1750°C	εC-r
	K (CA)	-200~1350°C	εC-ε
	E (CRC)	-200.0~700.0°C	εC-E
	J (IC)	-200.0~800.0°C	εC-J
	T (CC)	-200.0~400.0°C	εC-t
RTD	Pt100Ω (DIN)	-200.0~800.0°C	Pt
	JPt100Ω	-200.0~500.0°C	JPt
mA	0~20.0mA(-9999~9999)		āā
mV	-50.0~50.0mV(-9999~9999)		āu
V	-10.00~10.00V(-9999~9999)		ū
2-Wire	4~20mA(-9999~9999)		2ūr

### MODEL & SUFFIX CODE SELECTION

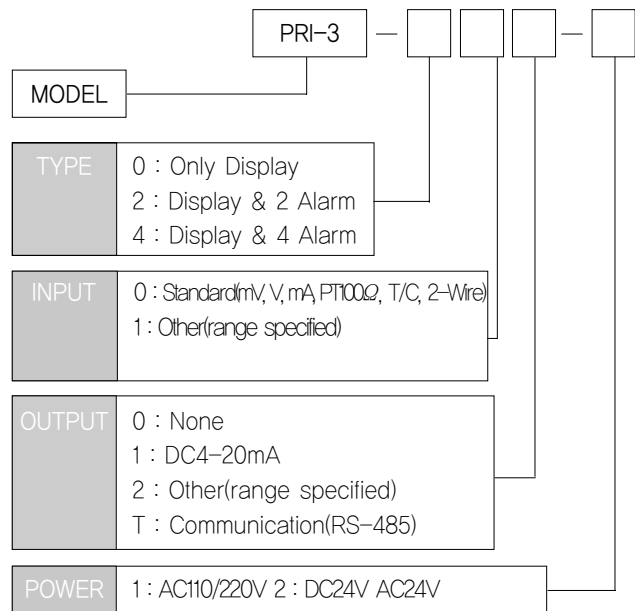

# INDICATOR PRI-3000 SERIES

## CONNECTION EXAMPLE

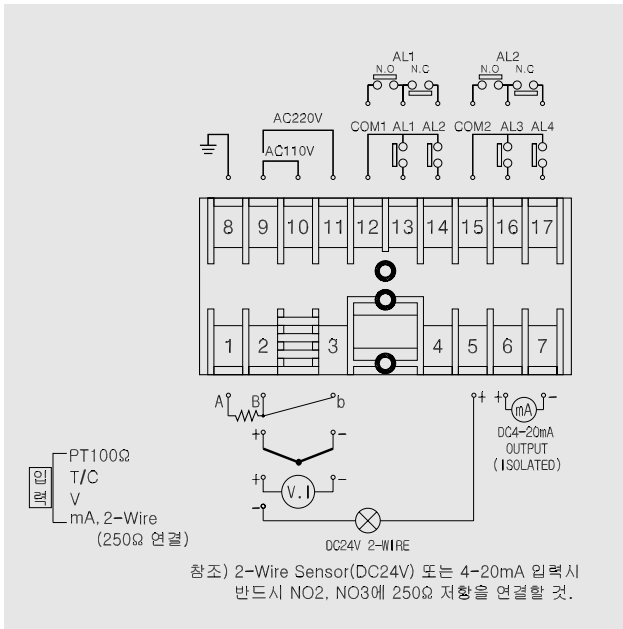

## Program Setting

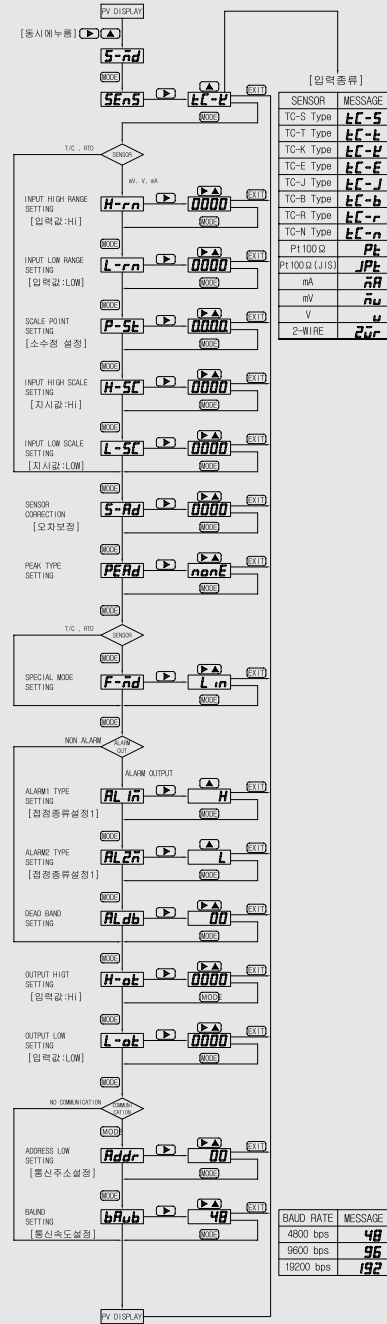

## PROGRAM CHART

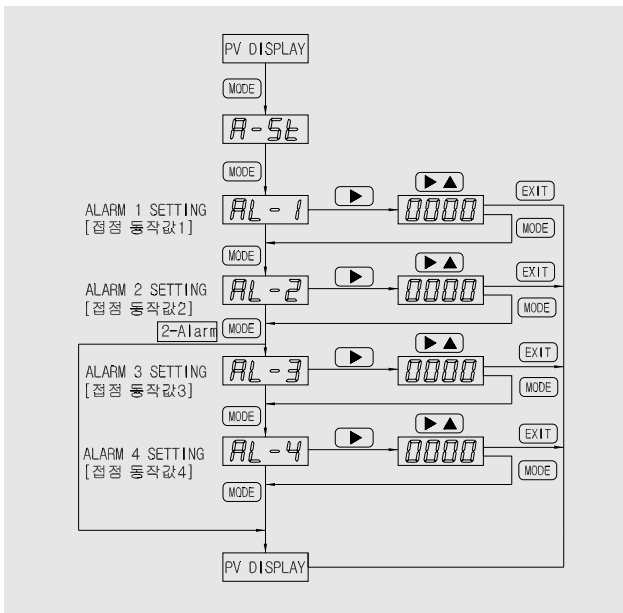

## DIMENSIONS (Unit : mm)

